



Integrated Valvejet 7 Dot Print Head

What am I getting? What are the improvements?

Diagraph is proud to release the new IV7 Dot print head. New features include:

- Environmentally Sealed housing for harsh environments
- External photocell can mount directly to the print head
- Compatible with existing IV700 Systems

What does the new print head replace?

The new IV 7 Dot print head will be a direct replacement for all IV 700 system print heads.

Can I get the old style print head?

Diagraph no longer manufactures the old style IV700 print head, only the new design is available for purchase part number 5770-202P (Porous) or 5770-202NP (Non Porous).

Will the new print head fit onto my existing IV700 System?

The new IV 7 Dot print head is backwards compatible with existing IV 700 controllers. Diagraph recommends upgrading the brackets to mount the new print head to the conveyor. Diagraph has released a more robust bracket that works with existing IV 700 systems. The part number for the recommended bracketry upgrade is 5760-821 \$85, an illustration of the bracket is on page 2 of this document. A power supply holster is also available, part number 5760-418, \$19.95.

An alternative to upgrading the bracketry is to drill two holes into the existing bracket in order to mount the new head to the existing vertical bracket.

Can I use my current ink?

The new IV 7 Dot is compatible with current ink being sold by Diagraph. Part numbers and descriptions of compatible ink are below:

Part Number	Color	Type	Quantity
5750-243	Black	TWP (Porous)	6 Pack
5750-244	Red	TWP (Porous)	6 Pack
5750-245	Blue	TWP (Porous)	6 Pack
5750-246	Green	TWP (Porous)	6 Pack
5750-242	NA	TWP Conditioner	2 Pack
5750-249	NA	TWP Maintenance Spray	2 Pack

Part Number	Color	Type	Quantity
5750-651	Black	TSO (Non Porous)	6 Pack
5750-652	Red	TSO (Non Porous)	6 Pack
5750-650	NA	TSO Conditioner	2 Pack
5750-657	NA	TSO Maintenance Spray	2 Pack

What should I change if I have an old style IV 700 print head?

Diagraph recommends upgrading the bracketry on existing IV 700 systems to the more robust 80/20 brackets, part number 5760-821. The 80/20 bracketry will allow for easier mounting of the new print head and increase the reach over the production line to get the new print head closer to the substrate.

Parts List:

5760-821 * Conveyor mounted bracket (Illustration below)

5760-418 * Power Supply Bracket Holster

5750-434 * IDS and Lower Controller Back Cover Kit (only if the serial number begins with NE) * If the controller serial number begins with E it must be replaced with a current model.

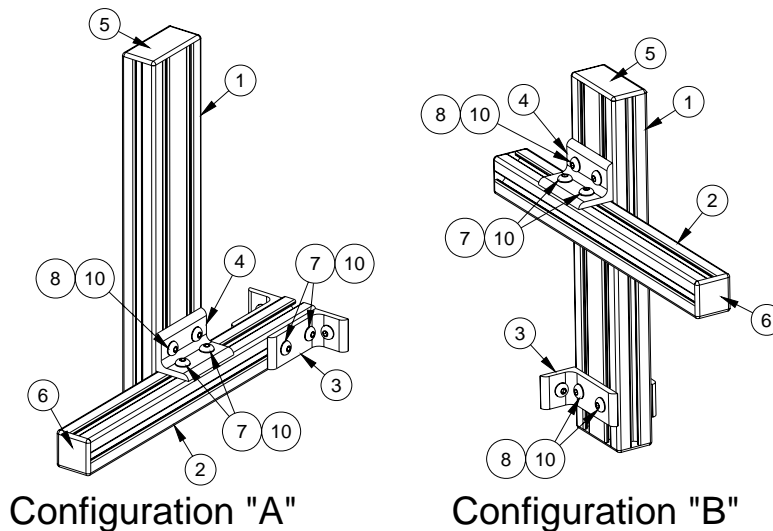

Will the new head plug in and print?

The new IV 7 Dot print head is backwards compatible with existing IV 700 systems.

How do I install the new head?

Installation instructions are included with this document.

See page 3.

Who do I call if I have more questions?

Diagraph Customer Service and Technical Support can be reached at 800-526-2531(7:00am -5:00pm CST). We are happy to help answer any questions you may have. You can also visit www.diagraph.com.

Precautions:



Always disconnect power when servicing equipment!



WARNING: Wear safety goggles when servicing the print system.

Valve	Dot Size	1st Dot
1	270	40
2	320	20
3	320	35
4	335	45
5	320	40
6	265	30
7	330	30

Column Dot = 0

Note: Before starting the installation, note the label on the bottom of the printhead. This label shows the optimal adjustments for printhead variables at the time of manufacture. Each printhead is unique and requires individual adjustments for optimal printing. Copy these values so you can enter them into the controller. At right is an example of the label. **DO NOT USE THE VALUES IN THIS SAMPLE LABEL.** Use the values on the label on your printhead.

Installation:

1. Remove the ink can and disconnect power from the controller.
2. Disconnect the cable and ink line from old printhead and remove printhead from bracketry.
3. Secure the new printhead to the bracketry and connect the cable and ink line from the controller. If the printhead being replaced is an old style printhead then refer to Detail A for the new mounting scheme.
4. Insert the ink can and power up the controller.
5. Place a clean wipe in front of the printhead and press the **PURGE** button. To remove all conditioner that ships inside a new printhead, continue to purge until you see a strong, saturated ink color on the cloth.

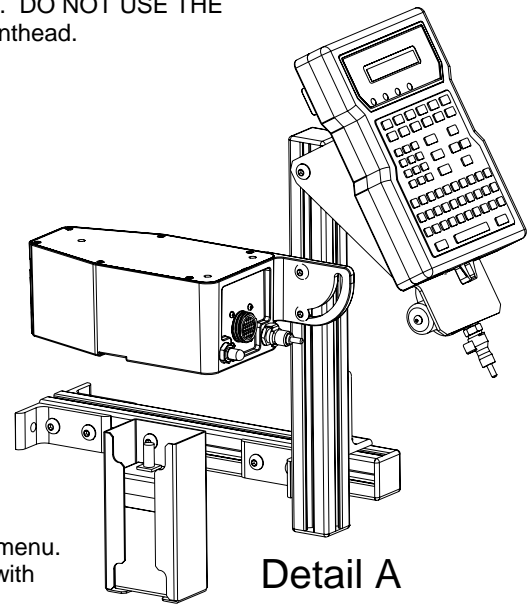

Detail A

Printhead Settings:

1. Disconnect power from the controller.
2. Simultaneously press **ALT + INFORMATION "i"** and power up the controller. Release the keys when the display shows the information menu.
3. Press the **SET-UP** button and the LCD will show the extended menu with additional choices.
4. Press the letter **I** and the LCD will show "Column Dot Adjust." Press **ENTER**.
5. Type the value from the bottom of the label identified as "Column Dot =" and press **ENTER**.
6. Press **SET-UP** then the letter **J**. The LCD will show "Dot: 1". The controller is waiting for a dot diameter value for the dot from the first valve in the printhead.
7. Refer to the "Dot Size" value for valve 1 on the printhead label and enter it at the prompt. Press **ENTER** when done. Repeat this operation for all seven valves.
8. After entering the value for dot 7, press **SET-UP**. The LCD will show "Factory Setting Y/N?" Select **2-YES**.
9. Press **SET-UP** then the letter **K**. The LCD will show "1st Dot Time: 000 sec". Accept this default time by pressing **ENTER**. If the controller shows a value other than zero, change the value to zero and press **ENTER**.
10. The LCD will display "1st Dot Adjust." 1" press **ENTER**.
11. The second line of the LCD will display "Dot Adjustment: 00". Refer to "1st Dot" for valve 1 on the printhead label and type it at the prompt. Press **ENTER** when done.
12. Repeat the procedure from steps 7 and 8 for all seven dots. After the seventh dot, press **SET-UP**. The LCD will prompt for "Factory Setting Y/N". Select **2 = YES**.

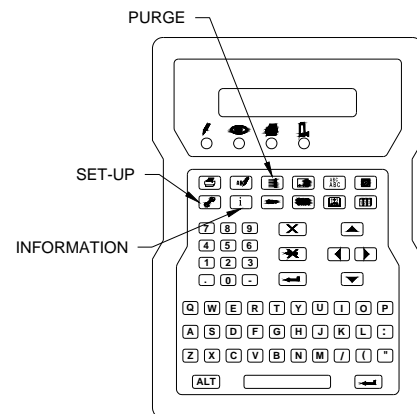

Printing Problems:

Do not make any adjustments described in this section until you have eliminated incorrect settings on the controller as a probable source of the problem.

One or more of the printhead dots is consistently too small or too large.

Single Dot Diameter Adjustment

This function allows you to change the dot diameter of individual dots by altering the stroke, in microseconds, of a piston in an ink channel.

1. Disconnect power from the controller.
2. Press and hold **ALT + INFORMATION** and power up the controller. Release the keys when the display shows the information menu.
3. Press the **SET-UP** button and the LCD will show the extended menu with additional choices.
4. Press the letter **J**. The LCD will prompt for the number of the dot that is not printing like the other dots. The top dot on the printhead is number 1 and the bottom dot is number 7.
5. Scroll to the number of the problem dot using the up and down arrow keys and press **ENTER**.
6. The LCD will prompt for a new diameter of the selected dot. Move to the second digit (250) and scroll to a new value. The scroll changes by units of 10.
7. Press **SET-UP**. The LCD will ask if you want to keep the "Factory Setting Y/N?" select **1-NO**. When you select **NO**, the controller remembers the new dot diameter value only until the next initialization. By running print samples and altering the diameter of a single dot, you can make that single dot match the appearance of the other dots.
8. When you achieve the best print, select **2-YES** when exiting this function. This choice makes the new pulse width value permanent.

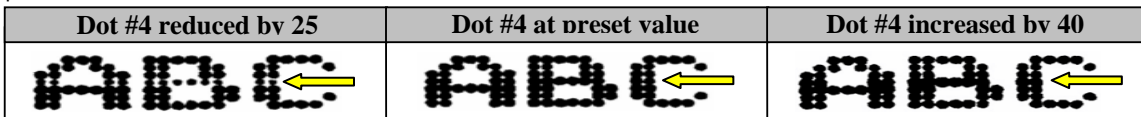

After sitting idle for several minutes, the initial prints have dots that are too small.

First Dot Adjustment

This procedure allows you to overcome this problem by independently increasing dot sizes exclusively on the first print. Second and all subsequent prints return to their defined dot size settings.

1. Disconnect power from the controller.
2. Press and hold **ALT + INFORMATION** and power up the controller. Release the keys when the display shows the information menu.
3. Press the **SET-UP** button and the LCD will show the extended menu with additional choices.
4. Press the letter **K**. The LCD will prompt for the time in seconds that the printer will stand idle.
5. Type the amount of time and press **ENTER**.
6. The LCD will show "1st Dot Adjust:1" for the first valve (dot) at the top of the printhead. Press **ENTER**. The second line of the LCD will prompt for "Dot Adjustment." If this dot is small in the sample print, increase the value by 10 which increases the size of the dot for the first print. If the dot was full-size, **DO NOT** enter a new value: leave the existing value and press **ENTER**.
7. The display will change to "1st Dot Adjust:2" for the second valve. Press **ENTER** and the second line will prompt for "Dot Adjustment." Repeat this process through all seven dots.
8. After the seventh dot, press **SET-UP**. The LCD will prompt for "Factory Setting." Select **2-YES**. Wait the time designated in step 3, then print a message. If the print is satisfactory, unplug and re-plug to set the controller in print mode. If the print is unsatisfactory reset the first dot by repeating this procedure and run another sample. Repeat until you achieve a satisfactory first print.

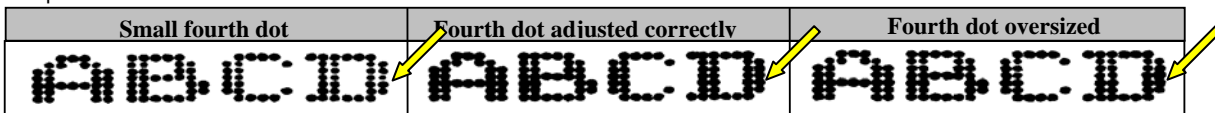

Noticeable size differences between dots printed in rows and dots printed in columns

Column Dot Adjustment

When the system prints a single dot, the printing channel has individual access to ink pressure. When all seven channels print simultaneously, they share the ink pressure. This sharing can produce printed dots in columns that are slightly smaller in diameter than single printed dots. The column dot adjustment enables you to eliminate slight size variances between dots printed in rows and dots printed in columns.

1. Disconnect power from the controller.
2. Press and hold **ALT + INFORMATION** and power up the controller. Release the keys when the display shows the information menu.
3. Press the **SET-UP** button and the LCD will show the extended menu with additional choices.
4. Press the letter **I**. The LCD will prompt for a change in value of the column dot adjustment.
5. Scroll to a higher or lower number using the up and down arrow keys and press **ENTER**.
6. Run a print sample at the speed of a production run.
7. Continue adjusting until the dots in columns match the size of dots printed in rows.

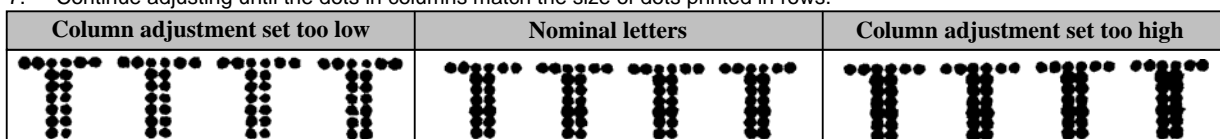

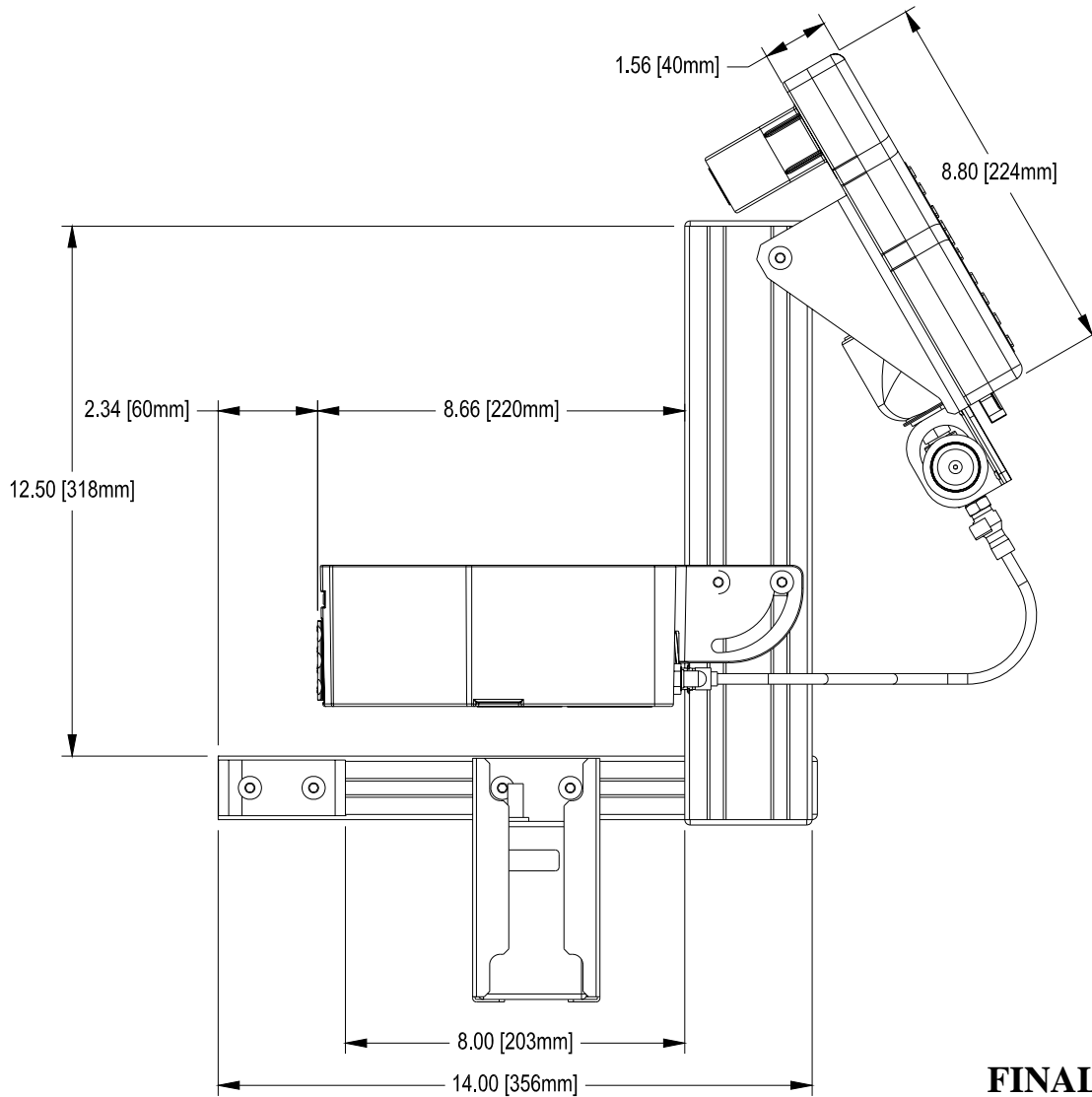
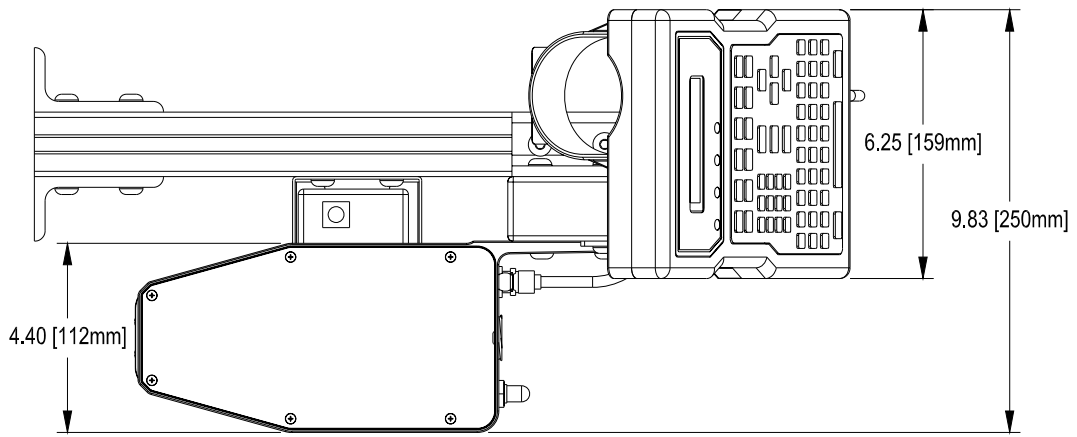

FINAL ASSEMBLY

ITEM	PART NUMBER	DESCRIPTION	QTY
1	5760-401X01400	BAR, 1.5" X 3" X 14" LONG	1
2	5760-400X01400	BAR, 1.5" X 1.5" X 14" LONG	1
3	5760-403	BRACKET, CORNER, 3 HOLE	2
4	5760-402	BRACKET, CORNER, 4 HOLE	1
5	5760-415	END CAP, 1.5" X 3"	2
6	5760-404	END CAP, 1.5" X 1.5"	2
7	5760-405	T-NUT, DOUBLE, 5/16-18	3
8	5760-406	T-NUT, SINGLE, 5/16-18	8
9	5305-026	NUT, 5/16-18 HEX	2
10	5310-730	SCREW, 5/16-18 X 5/8 BUTTON HD CAP, SS	10
11	5081-521	SCREW, 5/16-18 X 1-1/2 SOC HD CAP, SS	2
12	5310-308	WASHER, 5/16 LOCK	2
13	5310-033	WASHER, 5/16 FLAT	2

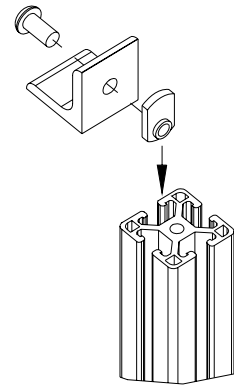

Note: This bracket kit can be assembled in two different configurations and can be used to mount either a 9 dot print head or a 7 dot print system.

Items 9, 11, 12, and 13 are used to fasten the bracket assembly to the side of the conveyor.

CAUTION: When the print system is setup in configuration "B" it may be possible for the carton being printed to make contact with the ink can.

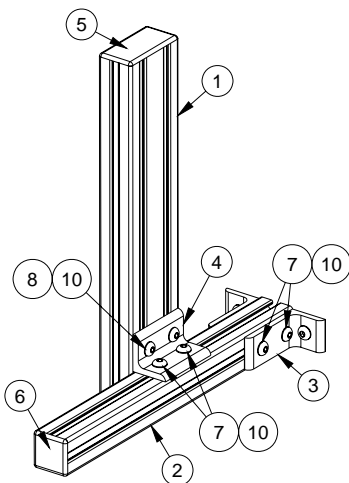
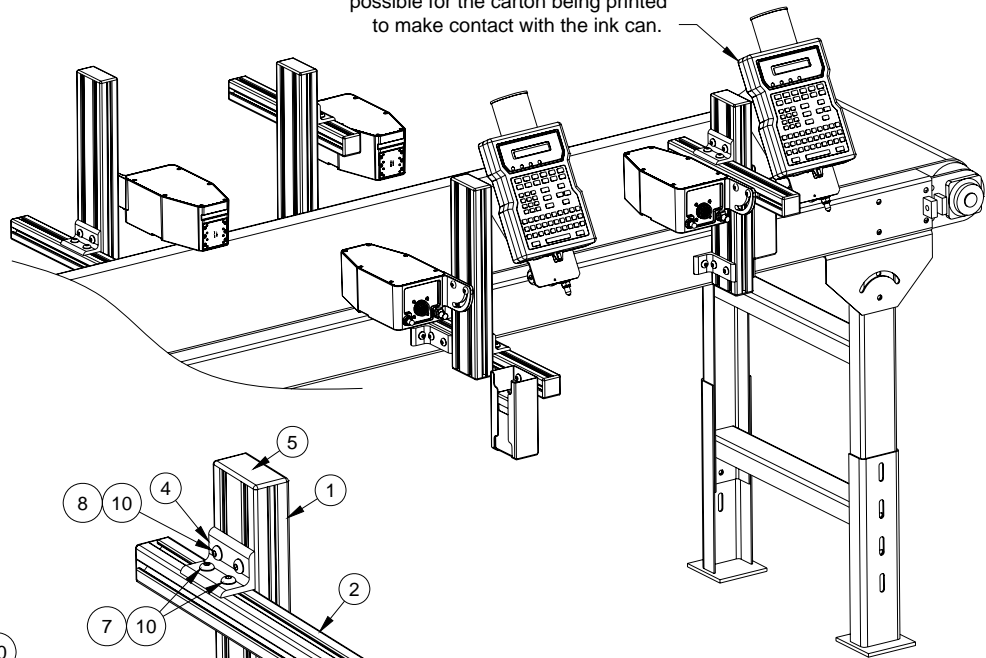

Configuration "A"

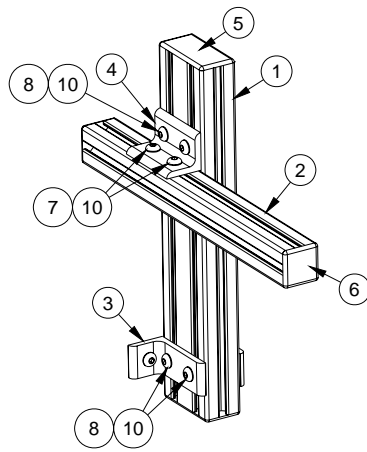

Configuration "B"