

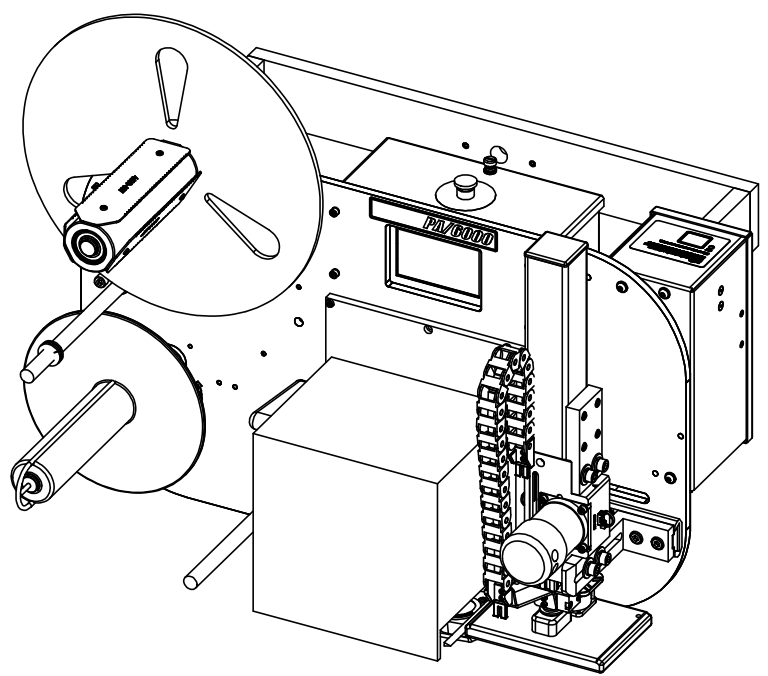



8 7 6 5 4 3 2 1

D  
C  
B  
A

D  
C  
B  
A



|   |  |   |  |   |  |   |  |
|---|--|---|--|---|--|---|--|
| <b>CONFIDENTIAL</b>   |  | UNLESS OTHERWISE SPECIFIED:   |  | FILE NAME<br>PA6000_E-SERIES_WITH-STAND |  |    <b>Diagraph.</b><br>An <i>ITW</i> Company |  |
| THIS DOCUMENT CONTAINS CONFIDENTIAL INFORMATION OF DIAGRAPH - AN ITW COMPANY AND IS NOT TO BE COPIED, USED OR DISCLOSED TO OTHERS WITHOUT THE EXPRESS WRITTEN CONSENT OF DIAGRAPH - AN ITW COMPANY. |  | ALL DIMENSIONS ARE SHOWN IN INCHES. ALL DIMENSIONS APPLY AFTER FINISH. REMOVE BURRS |  | DWN<br>R BIXEN                          |  |   |  |
|   |  | TOLERANCES:   |  | APP<br>XX                               |  | APP<br>XX   |  |
|   |  | LINEAR 2 PLACE (.XX) ±.015  |  | APP                                     |  | TITLE:  |  |
|   |  | 3 PLACE (.XXX) ±.005  |  | ASSY PROC                               |  | PA6000, E-TAMP, RH, 5-IN,<br>TOP-DOWN   |  |
|   |  | HOLE DIAMETERS ±.005  |  | INSP PROC                               |  |   |  |
|   |  | ANGULAR ±1°   |  | CAGE CODE                               |  | SIZE  |  |
|   |  | MACHINE SURFACE   |  | SCALE: 1:8                              |  | DWG NO  |  |
| NEXT ASSEMBLY   |  | MATL SPEC   |  | SHEET 1 OF 3                            |  | XX  |  |
| MODEL   |  |   |  |   |  | REV   |  |
|   |  |   |  |   |  | 0   |  |

8 7 6 5 4 3 2 1

8 7 6 5 4 3 2 1

D

D

C

C

B

B

A

A

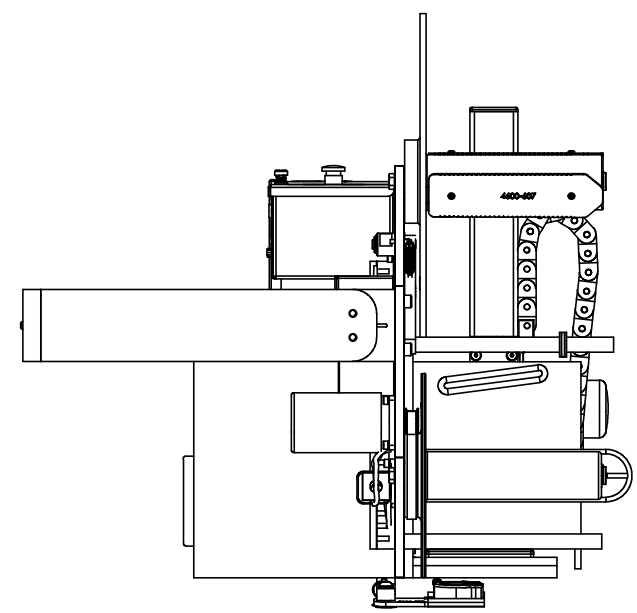

LEFT VIEW

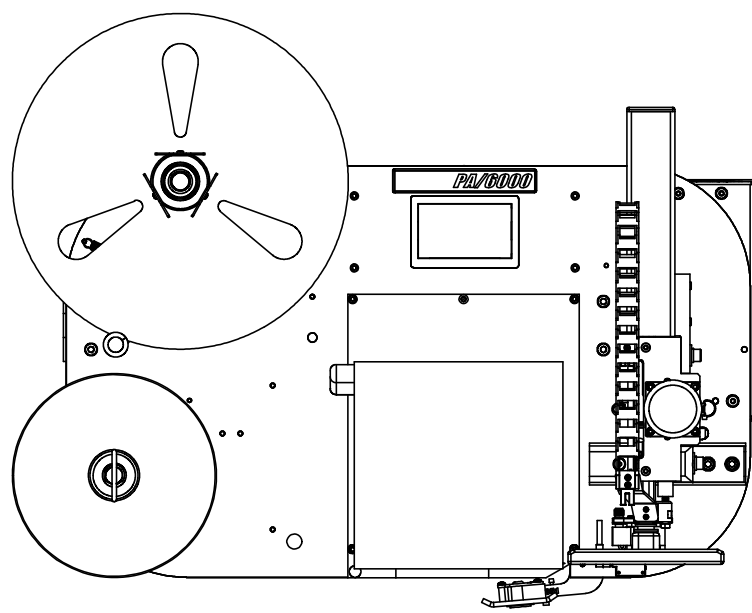

FRONT VIEW

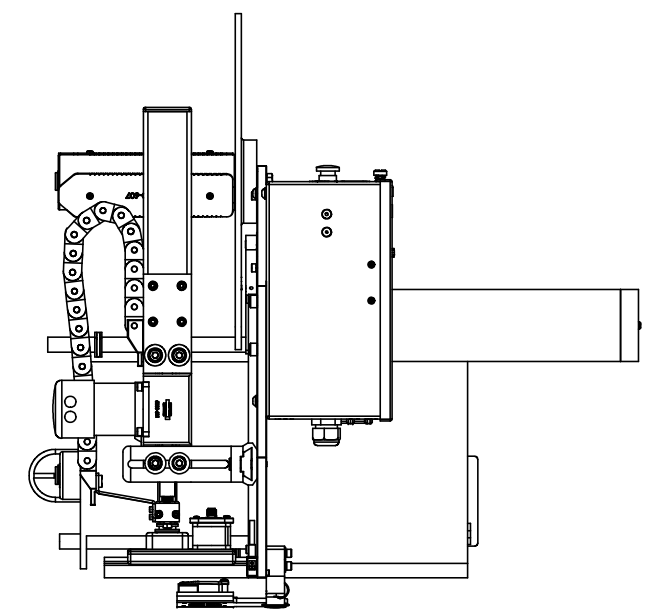

RIGHT VIEW

|                                       |      |              |     |
|---------------------------------------|------|--------------|-----|
| <br><b>Diagraph</b><br>An ITW Company | SIZE | DWG NO       | REV |
|                                       | B    | XX           | 0   |
| SCALE: 1:8                            |      | SHEET 2 OF 3 |     |

8 7 6 5 4 3 2 1

8 7 6 5 4 3 2 1

D

D

C

C

B

B

A

A

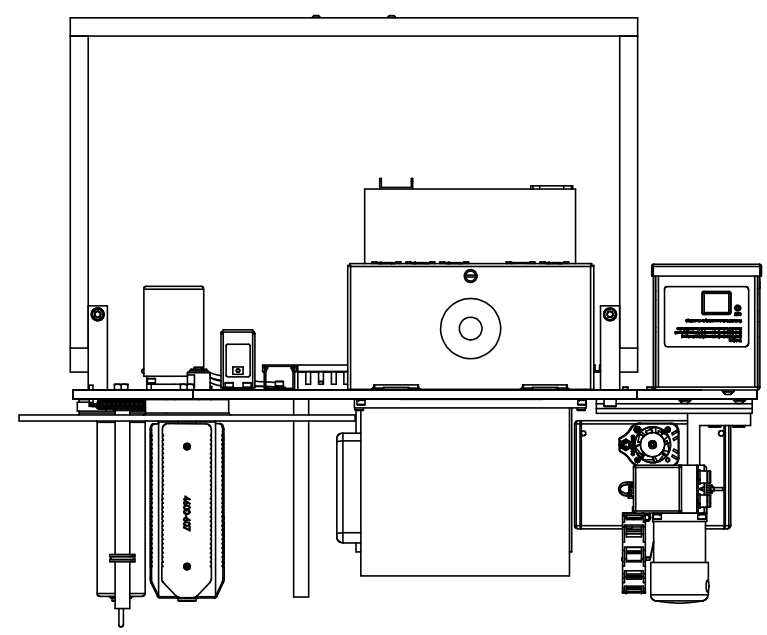

TOP VIEW

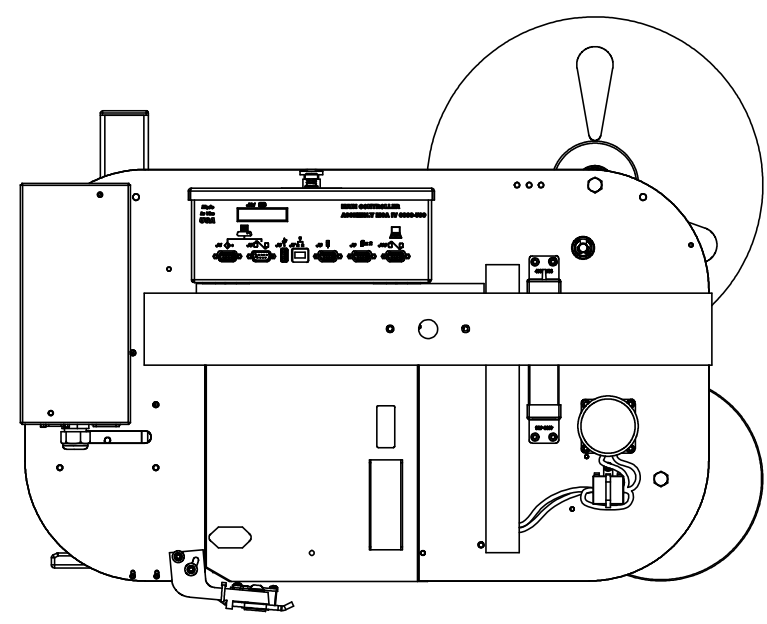

REAR VIEW

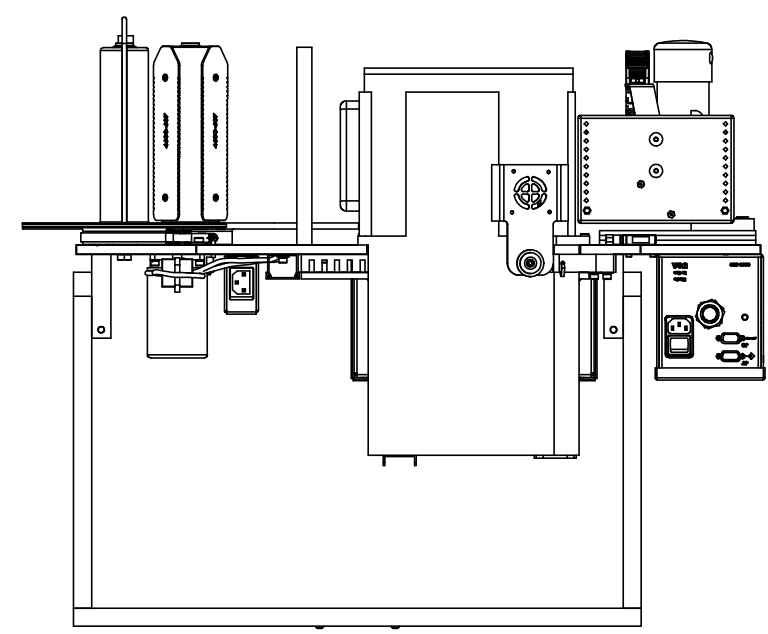

BOTTOM VIEW

|            |      |              |     |
|------------|------|--------------|-----|
|            | SIZE | DWG NO       | REV |
|            | B    | XX           | 0   |
| SCALE: 1:8 |      | SHEET 3 OF 3 |     |

8 7 6 5 4 3 2 1